

## Harmonic distortion characteristics generated by heating ventilation air conditioning system case study in PCR Laboratory

Reza Andika Setyadi\* and Rudy Setiabudy

Department of Electrical Engineering, Faculty of Engineering, Universitas Indonesia, **Indonesia**

\*Corresponding Author: [rezaandika692@gmail.com](mailto:rezaandika692@gmail.com)

Received 7<sup>th</sup> Jan 2023; 1<sup>st</sup> Revision 10<sup>th</sup> Jan 2023; 2<sup>nd</sup> Revision 28<sup>th</sup> Jan 2023; Accepted 23<sup>rd</sup> Feb 2023

 Cite this <https://doi.org/10.24036/jptk.v6i1.31323>

**Abstract:** Good power quality is required in health facilities since the increasing use of microprocessor-based equipment. Poor power quality in the electric power system can cause medical equipment in health care centers to malfunction and give incorrect medical diagnoses. Since 2020 we are facing a new type of Virus (Covid-19), this virus requires special laboratory construction with specific air conditioning systems (temperature, humidity, and pressure) to process specimens. This paper presents measurement results of harmonic distortion characteristic by Variable Frequency Drive (VFD) of Heating Ventilation Air Conditioning (HVAC) system in PCR Laboratory at Clinic A. The VFD in this system is used to adjust the rotation of the exhaust fan and outdoor unit. The measured voltage, current and power are used to assess power quality. The main power quality problems found in medical facilities are voltage flicker, neutral currents, and total harmonic distortion (THD) values. The measurement of total harmonic distortion (THD) is used to find the source of the harmonics. Potential problems can be identified within the facility. The results of this study can be used to develop, test, and validate the system that has been used.

**Keywords:** Power quality; HVAC; PCR Laboratory; Harmonic; VFD

### 1. Introduction

The demand for setup rooms with specific temperature, humidity, and pressure has grown since these three factors are keys to creating an ideal laboratory conditions. And also currently we are facing Covid-19 that needs a specific room requirements to process a specimen. False setting humidity or pressure could affect the accuracy of sensitive tests. In other hand, the right setting of temperature will ensure samples aren't contaminated. This kind of requirements need supports from HVAC system. The HVAC system basically only could support temperature settings, currently we have Variable Frequency Drive (VFD) to support indoor unit fan and exhaust fan modulation to achieve temperature and pressure requirements. VFD also known as inverters, is an application solutions for motor that require further control capabilities, for example: setting the motor rotation according to the load or according to the desired value. The use of VSD can be for AC or DC motor applications. The term inverter is often used for AC applications. However, this equipment relies heavily on switching components which in this system we used VFDs to achieve the temperature and air humidity requirements. VFD is a non-linear load and generates harmonics when operated.

Harmonic distortion is one of the power quality problems in the electric power system. The

harmonics degrade the power quality of an electric power system. Harmonic distortion in an electric power system is caused by a current flowing through a non-linear load which produces a current wave on the source side with a non-sinusoidal shape (Dugan et al., 2012; Harrison, 2010; Pinyol, 2015). Harmonics are periodic sinusoidal distortions of the supply voltage or load current caused by nonlinear loads. Harmonics are measured in integer multiples of the fundamental supply frequency. Voltage or current waveforms assume nonsinusoidal shape. Harmonics issues are of great concern to engineers and building designers because they can do more than distort voltage waveforms, they can overheat a building's wiring, cause nuisance tripping, overheat transformer units, and cause random end-user equipment failure (Mikkili & Panda, 2015). Many devices and appliances are sensitive, hence any such harmonics or PQ (Power Quality) issues might damage them or stop them from performing properly. We noted that IEEE std 519 in 1992 had ever listed a low limit for special application including hospital and airport that we know all the medical facilities have a critical and sensitive equipments. However currently in new edition of IEEE std 519-2022 had equate all categories to single limit harmonic distortion. Table 1 shown limitation of voltage harmonic and Table 2 shown current harmonic limitation based on IEEE std 519-2022.

Table 1. Voltage Distortion Limit (Committee, 2022)

Bus voltage V at PCC	Individual harmonic (%) $h \leq 50$	Total harmonic distortion THD (%)
$V \leq 1.0$ kV	5.0	8.0
$1 \text{ kV} < V \leq 69$ kV	3.0	5.0
$69 \text{ kV} < V \leq 161$ kV	1.5	2.5
$161 \text{ kV} < V$	1.0	1.5 <sup>a</sup>

High-voltage systems are allowed to have up to 2.0% THD where the cause is an HVDC terminal whose effects are found to be attenuated at points in the network where future users may be connected.

Table 2. Current distortion limits for systems rated 120 V through 69 kV (Committee, 2022)

Maximum harmonic current distortion in percent of $I_L$						
Individual harmonic order <sup>b</sup>						
$I_{sc}/h$	$2 \leq h < 11^a$	$11 \leq h < 17$	$17 \leq h < 23$	$23 \leq h < 35$	$35 \leq h \leq 50$	TDD
$< 20^c$	4.0	2.0	1.5	0.6	0.3	5.0
$20 < 50$	7.0	3.5	2.5	1.0	0.5	8.0
$50 < 100$	10.0	4.5	4.0	1.5	0.7	12.0
$100 < 1000$	12.0	5.5	5.0	2.0	1.0	15.0
$> 1000$	15.0	7.0	6.0	2.5	1.4	20.0

<sup>a</sup> For  $h \leq 6$ , even harmonics are limited to 50% of the harmonic limits shown in the table.

<sup>b</sup> Current distortions that result in a dc offset, e.g., half-wave converters, are not allowed.

<sup>c</sup> Power generation facilities are limited to these values of current distortion, regardless of actual  $I_{sc}/I_L$  unless covered by other standards with applicable scope. where:  $I_{sc}$  = maximum short-circuit current at PCC;  $I_L$  = maximum demand load current at PCC under normal load operating conditions.

This paper will be important as reference to object clinic and all medical facilities who wants to construct HVAC-VFD system to meet room requirements, therefore the organization could consider to install other support component to eliminate harmonic issues.

## 2. Methods

This study presents the results of measurement and analysis of power quality problems in the form of harmonics in the electric power system of the AHU unit that equipped with VFD in the PCR Laboratory room of a health facility (clinic). VFD which is the object of this research is a non-linear load that functions is to modulate the rotation of the electric motor from the indoor unit and exhaust fan. A single line diagram of the air conditioning system in the PCR Laboratory Clinic A is shown in Figure 1. We can see that two VFDs are used to adjust the indoor unit fan and exhaust to meet indoor air requirements. Table 3 shows the specifications of the VFD used as objects in this study.

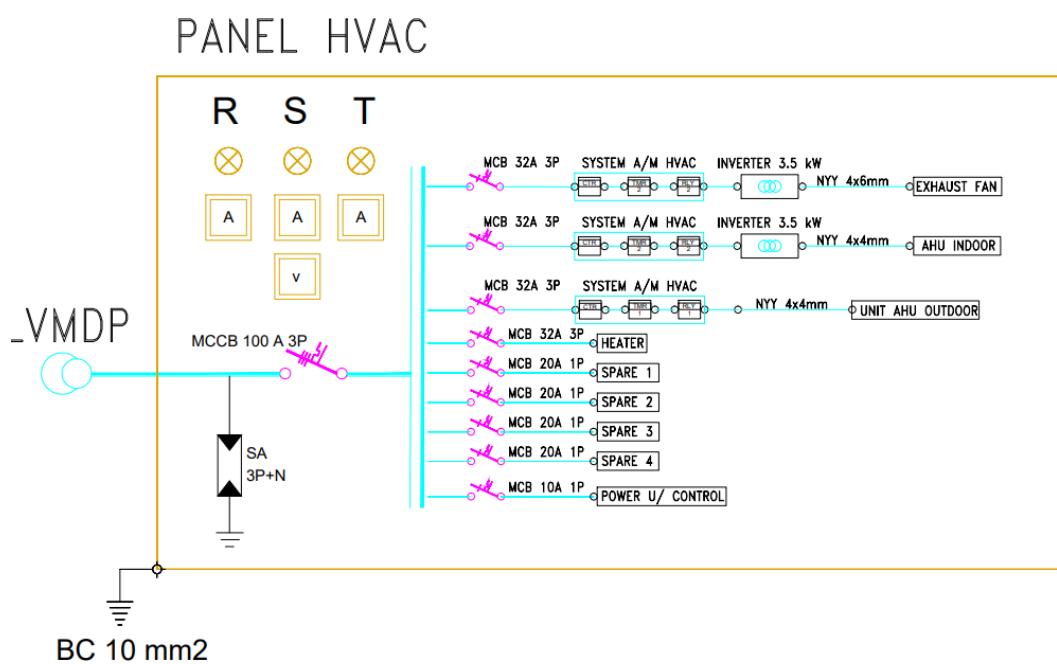

Figure 1. Single Line Diagram of HVAC Panel

Table 3. VFD Specification

<b>[Us] rated supply voltage</b>	380...500 V - 15...10 %
<b>nominal output current</b>	14.3 A
<b>motor power kW</b>	5.5 kW for heavy duty
<b>EMC filter</b>	Class C2 EMC filter integrated
<b>IP degree of protection</b>	IP20
<b>maximum output frequency</b>	0.599 kHz
<b>transient overtorque</b>	170...200 % of nominal motor torque
<b>switching frequency</b>	2...16 kHz adjustable 4...16 kHz with derating factor
<b>nominal switching frequency</b>	4 kHz
<b>line current</b>	20.7 A at 380 V (heavy duty)

	14.5 A at 500 V (heavy duty)
<b>maximum input current</b>	20.7 A
<b>maximum output voltage</b>	500 V
<b>apparent power</b>	12.6 kVA at 500 V (heavy duty)
<b>network frequency</b>	50...60 Hz
<b>relative symmetric network frequency tolerance</b>	5 %
<b>prospective line Isc</b>	22 kA
<b>base load current at high overload</b>	14.3 A
<b>power dissipation in W</b>	Fan: 195.0 W at 380 V, switching frequency 4 kHz

In this study a power quality analyzer brand H equipped with 4 voltage clamps & 3 amperage clamps is used to measure and record data of power quality including harmonics. Figure 2 shows the wiring scheme from the measuring device to the electrical installation of the HVAC panel. Measurements were carried out for 4 days non-stop using a power quality analyzer at the HVAC panel of the PCR Laboratory.

Measurements were taken on 22 – 25 October 2022 at the HVAC Panel of PCR Laboratory Clinic A. PQA brand H can be adjusted as needed, the tool settings in this study are shown in table 4.

Table 4. Power Quality Analyzer Setup

Parameter	Settings	Notes
Wiring	3P4W	3 Phase, 4 Wire
Voltage	U123	
Range	600 V	
VT (PT)	1.00	No VT
Current	CH123	
Range	5 A	
CT	20	CT 100/5 A
Sensor	9694	Clamp Ampere Type
Interval Time	1 min	Record every 1 minute
Norm. Meas	Inst. On; Ave. On	
Harmonic	Max. On; Min. On	
Meas. Start	Manual	
Meas. Stop	Automatic	Time: 2022/10/25 11:00

Figure 2 shows the PQA wiring setup at the HVAC Panel. After the wiring has been connected according to Figure 2.a. then you can look at the PQA to check the measuring cable connection. After all parameters of the measuring cable connection have been read as "ok" on the PQA, the measurement can be started, in this measurement the PQA is set to start the measurement manually and stop automatically.

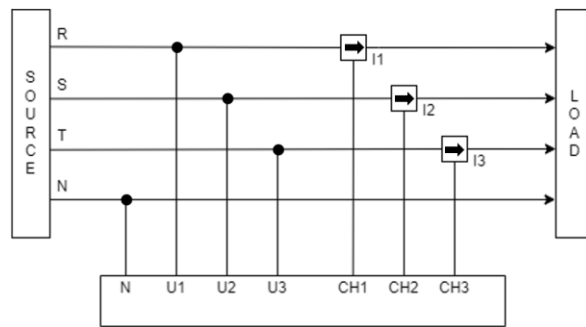

(a)



(b)

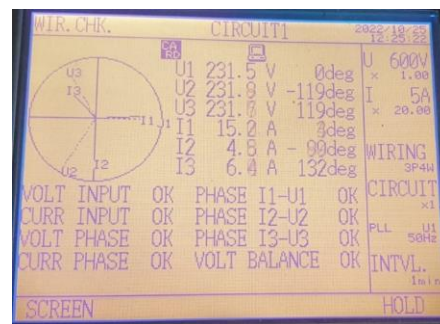

(c)

Figure 2. (a) Measurement wiring setup diagram, (b) Measurement wiring setup on panel, and (c) Power Quality Analyzer wiring check

### 3. Results and discussion

Based on measurement data on the HVAC Panel on 22 – 25 October 2022, the load characteristic results are obtained shows on Table 5. The maximum current measurement result is 86.75 A which will then be used in the calculation  $\frac{I_{SC}}{I_L} = \frac{22,000}{86.75} = 253.6 A$  and *Total Demand Distortion* (TDD) with formula:

$$TDD = \sqrt{\frac{\sum_{h=2}^{\infty} (I_h)^2}{I_{Lmax}}} \quad (1)$$

Table 5. Load profile measurement

Parameter	Value
$V_R$	232.97 V
$V_S$	233.05 V
$V_T$	232.26 V
$I_{Rmax}$	80.41 A
$I_{Smax}$	86.75 A
$I_{Tmax}$	83.99 A
$P_{max}$	47,274 W
$Q_{max}$	33,791 VAR
$S_{max}$	54,828 VA
$f_{average}$	50.02 Hz
$PF_{average}$	0.91
$h_{v-max}$	1.99%
$h_{i-max}$	97.48% (orde 5)

Based on Table 6, it can be seen that the Total Harmonic Distortion (THD<sub>v</sub>) and Total Demand Distortion (TDD) values of the PCR laboratory HVAC system are still below the IEEE std 519-2022 standard "IEEE Recommended Practices and Requirements for Harmonic Control in Electrical Power Systems". With a maximum THD<sub>v</sub> value of 2.3% on the 3<sup>rd</sup> day of measurement at 08:08 WIB, it is still below the standard by a maximum THD<sub>v</sub> of 8% for a voltage value on PCC below 1.0 kV. Likewise, the maximum TDD value recorded at 10.41% on the 3<sup>rd</sup> day of measurement at 20:24 WIB is still below the standard by a maximum TDD of 15% for voltage values in the range 120 V – 69 kV and I<sub>sc</sub>/I<sub>L</sub> in the range 100<1000.

Table 6. Measurement Result of THD<sub>v</sub> dan TDD (Maximum)

Day		1	2	3	4	Average
T H D	V <sub>R</sub> (%)	1.83	1.9	<b>2.3</b>	2.18	2.05
		17:47	03:50	<b>08:08</b>	09:01	
	V <sub>S</sub> (%)	1.46	1.65	1.87	1.83	1.70
		08:33	04:08	08:08	09:04	
	V <sub>T</sub> (%)	1.51	1.66	1.86	1.83	1.72
		08:45	04:03	08:15	03:44	
T D D	I <sub>R</sub> (%)	10.23	10.15	<b>10.41</b>	9.47	10.07
		11:16	13:26	<b>20:24</b>	05:28	
	I <sub>S</sub> (%)	10.11	10.15	10.00	9.61	9.97
		21:10	00:33	00:09	07:03	
	I <sub>T</sub> (%)	6.06	6.01	6.12	5.97	6.04
		21:10	00:19	21:24	05:42	

Figure 3 shows the curves of individual Phase R voltage harmonics on 3<sup>rd</sup> day at 08:08 WIB which was recorded as having the highest THD<sub>v</sub> value. It can be seen that no individual harmonics exceed the 5% limit value as required in IEEE std 519-2022.

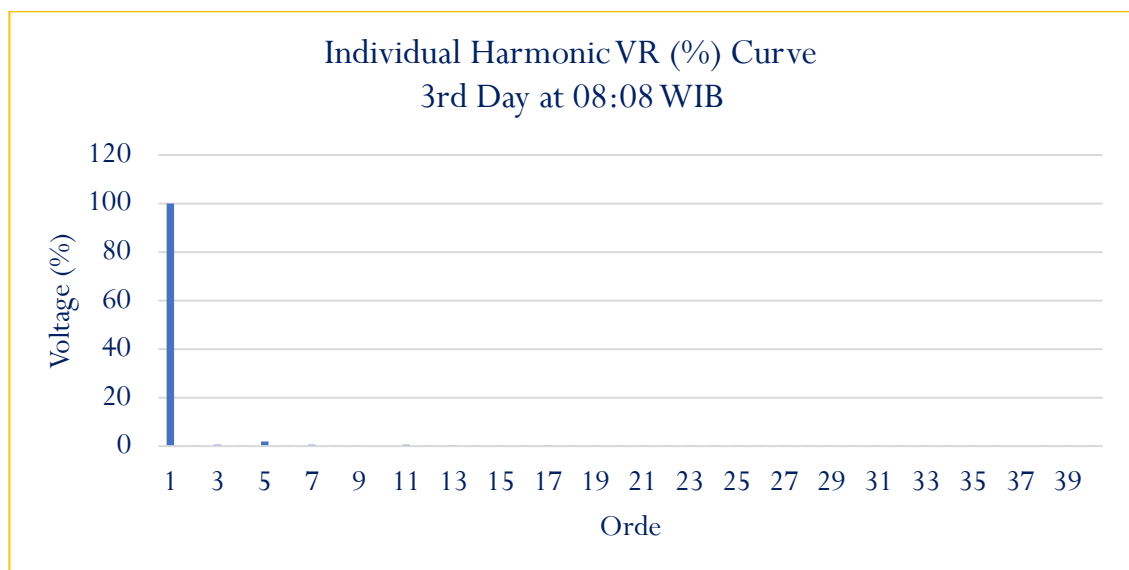
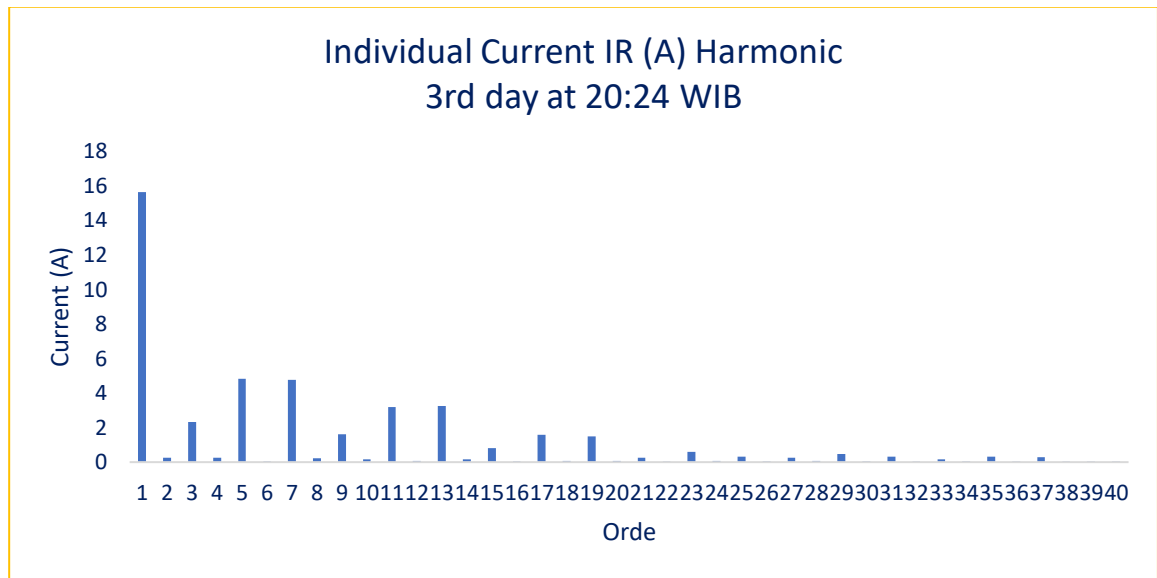
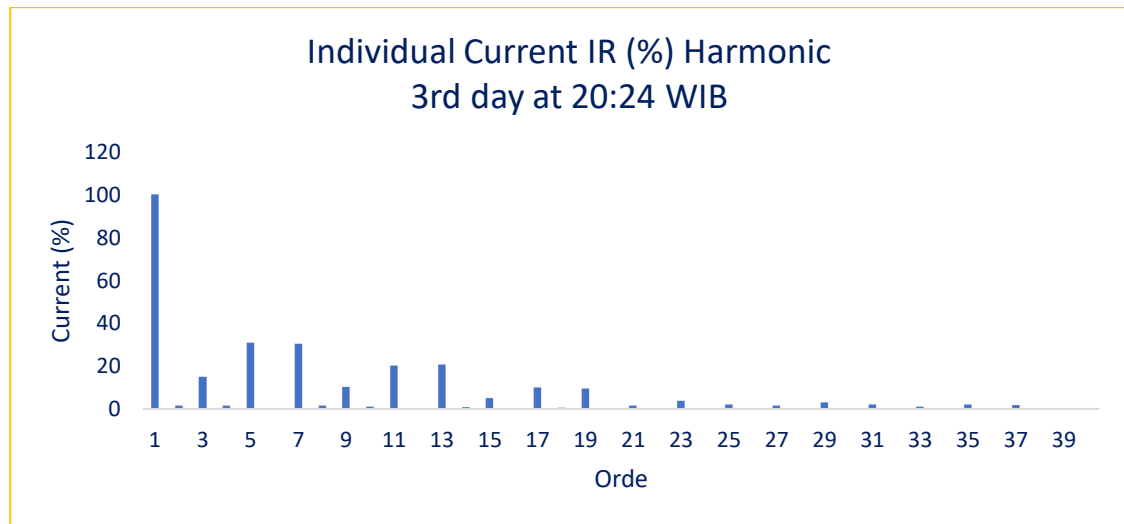

Figure 3. Individual Voltage<sub>R</sub> Harmonic (%) Measurement Curve on 3<sup>rd</sup> at 08:08 WIB

However, the individual current harmonic values shown in Figure 4 that only odd order multiples of 3 (except order 3) have individual current harmonic values below IEEE std 519-2022 considering that a 3-phase system does not generate triplen harmonics.



(a)



(b)

Figure 4. Individual Current ( $I_R$ ) Harmonics Measurement Curve on 3<sup>rd</sup> day at 20:24 WIB: (a). Current (A); (b). Current (%)

We processes the data obtained by the measurements to find the maximum individual harmonic values for each order and phase as shown in Figure 5 below. It can be seen that the current containing harmonics are dominant in odd orders except for multiples of 3.

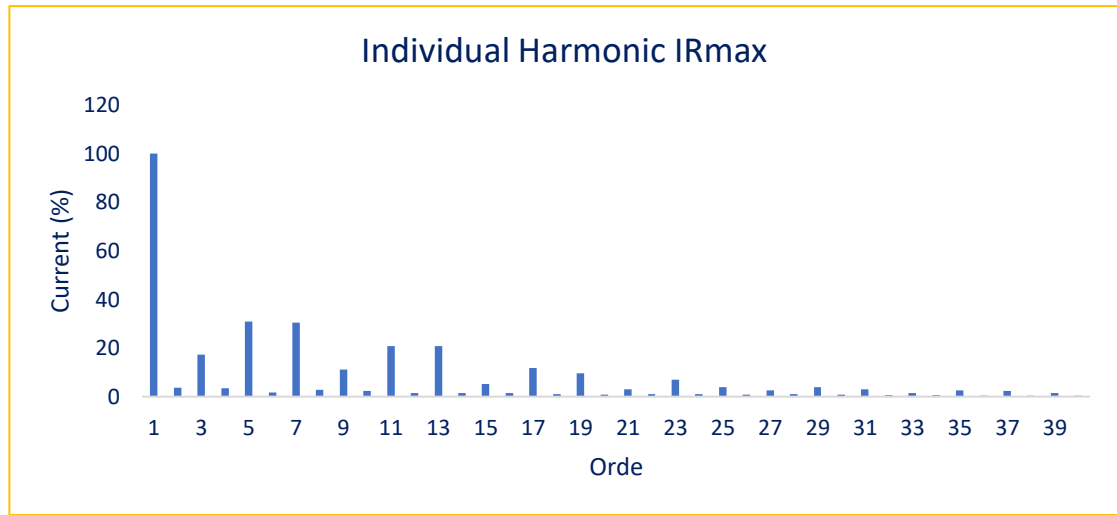

(a)

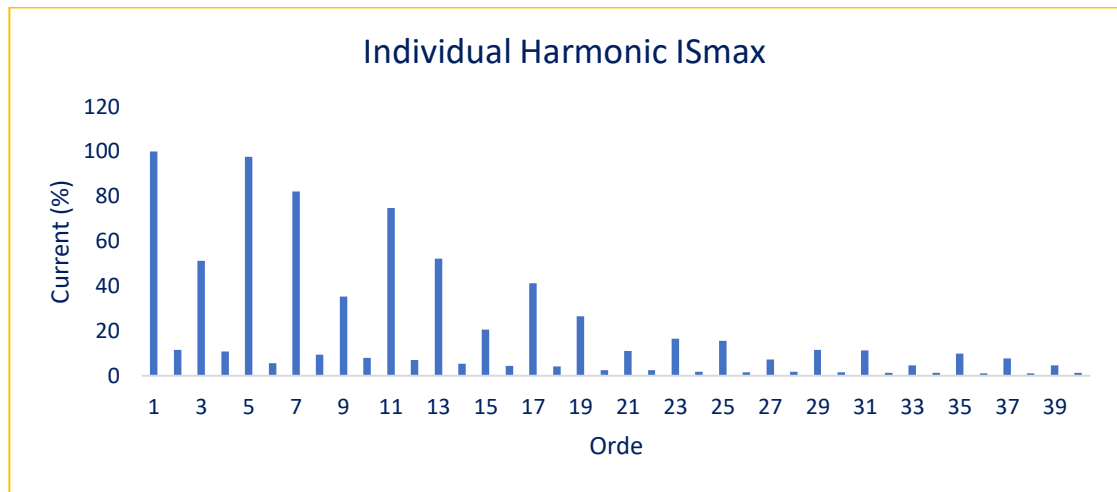

(b)

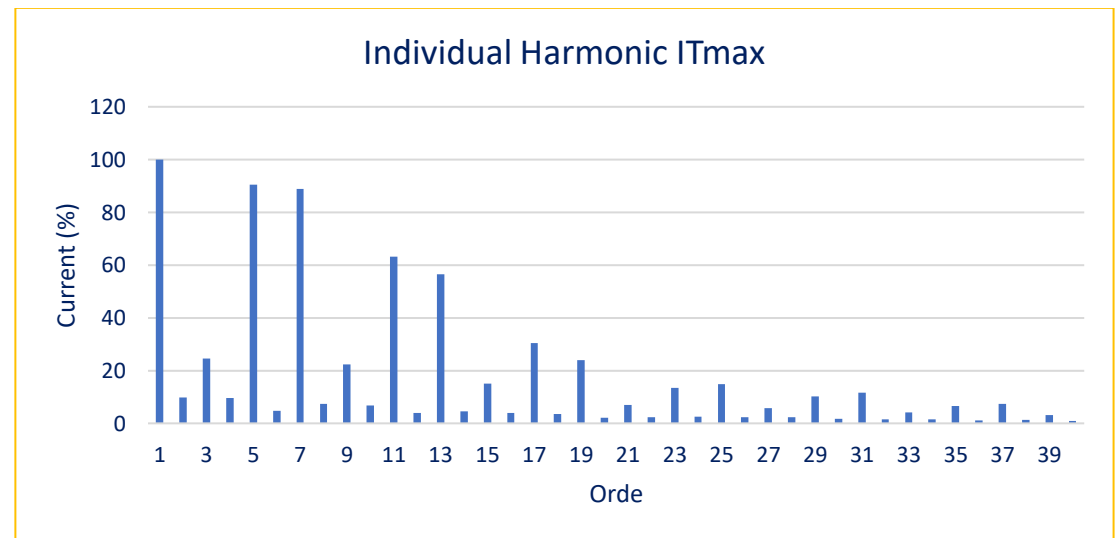

(c)

Figure 4. Individual Current Harmonic (Maximum): (a).  $I_R$  (%); (b).  $I_S$  (%); (c).  $I_T$  (%)



From the results of the research that has been done, no significant total harmonic distortion and voltage harmonics were found, with a maximum THDv value of 2.3% and individual voltage harmonics ( $h \leq 50$ ) of 1.99%, still below the standard required by IEEE Std 519-2022 of 5% for individual harmonic voltages and 8% for total harmonic distortion. While the current value obtained by the maximum TDD is 10.41% and the maximum individual harmonics is 97.48% (at order 5). The TDD value is still below the standard required by IEEE Std 519-2022 of 15%, but for individual harmonic values the current exceeded the required limit of 12% (for order  $2 \leq h < 11$ ).

Operationally the air conditioning system of the PCR Clinic A Laboratory is still relatively good, but consideration is needed to design a harmonic filter as a step to reduce current harmonics. Since harmonics could be the cause of nuisance trip on HVAC system or further more the motor may experience major damage.

#### 4. Conclusion

Based on the measurement, processing, and analysis of the data, it can be concluded that the use of a non-linear load in this case the VFD on the AHU unit in the PCR Laboratory Clinic A generates harmonic distortion in the current. This distorted current has harmonic content in odd orders other than multiples of 3 with the 5<sup>th</sup>, 7<sup>th</sup>, 11<sup>th</sup>, and 13<sup>th</sup> orders which are quite dominant. It is recommended for future research to study and conduct trials of harmonic filter designs to eliminate dominant harmonic distortions in several orders or to use other harmonic reduction methods.

#### References

- Committee, T. and D. (2022). IEEE Standard for Harmonic Control in Electric Power Systems. *IEEE Power and Energy Society*.
- Dugan, R. C., McGranaghan, M. F., Santoso, S., & Beaty, H. W. (2012). *Electrical Power systems Quality* (3rd ed.). McGraw-Hill.
- Harrison, A. (2010). *The Effects of Harmonics on Power Quality and Energy Efficiency* [Dublin Institute of Technology]. <https://arrow.tudublin.ie/engschelecon>
- Mikkili, S., & Panda, A. K. (2015). Power Quality Issues: Current Harmonics. In *Power Quality Issues: Current Harmonics*. <https://doi.org/10.1201/9781315222479>
- Pinyol, R. (2015). *Harmonics: Causes, effects and minimization*. Salicru white papers.